

1. INSTALL TIRES AND FENDERS

- Remove Hub shipping covers and install tires (cone side of lug nuts towards rim).
- Torque lug nuts 70-90 ft lbs. (check periodically to insure torque value is maintained).
- Note tail light quick-connect positions in left and right (curb) fenders. Select and position fenders with quick connects towards the inside. This allows the pre-wired harness to reach the tail lights.
- Bolt fenders to frame with 3/8" x 1" bolts provided in hardware package.
- Connect tail lights (2) to pre-wired harness (3 & 4).

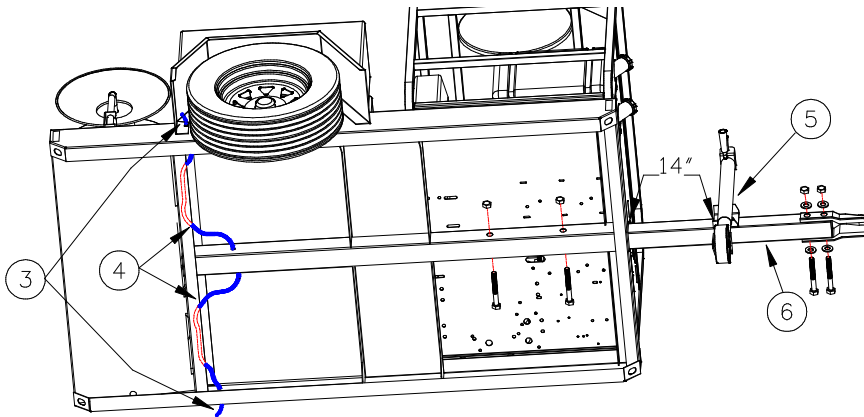
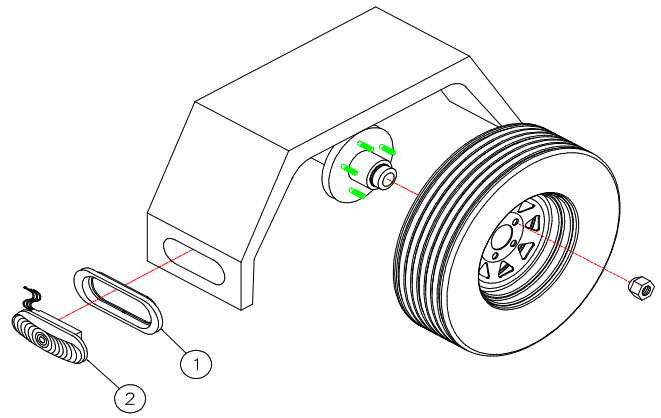

2. INSTALL TONGUE & JACK

- Pull tongue (6) from shipping position in frame and fasten with 5/8" x 4 1/2" bolts provided.
- Install bolt into aft most clearance holes.
- Install bolt into forward bolt holes. If necessary, lift tongue to align clearance holes. Install trailer coupler and fasten with 1/2" x 4 1/2" bolts provided. Use 1/2" x 2 1/2" bolts and nylon lock nuts provided for positive safety chain connection to tow vehicle.
- Fasten jack (5) to tongue approximately 14" from the frame.
Be sure there is sufficient clearance between the jack and frame when jack is swung to horizontal position.

3. INSTALL ACCESSORIES

- Remove corner shipping legs and return to Hydro Tek when convenient.
- Install 3/4" Faucet Valve in tank outlet plumbing.
- Install Safety red and amber safety reflectors. Amber on front sides and red in rear.

4. TRAILER CHECK

- RECHECK ALL BOLTS AND LUG NUTS TO MAKE SURE THEY ARE TIGHT.
- FILL TANK WITH WATER AND TEST MACHINE.
- DOUBLE CHECK SAFETY CHAINS, COUPLER LATCH, JACK POSITION AND ELECTRICAL CONNECTIONS BEFORE TRAILERING (SEE OPERATORS MANUAL)